

# Dual-Band WLAN Dual Diplexer 2.4–2.5 GHz and 5–6 GHz



DD113BC2

## Applications

- WLAN Systems Including 802.11a,b,g

## Features

- LTCC Technology
- Dual Diplexer
- SMD Package, 5.3 x 3.5 x 1.2 mm
- Dual-Band Diplex Receive, Dual-Band Diplex Transmit

## Description

The DD113BC2 is a ceramic dual diplexer for dual-band WLAN systems using LTCC design and manufacturing technology. The part consist of two diplexers, one for dual-band receive and one for dual-band transmit. The design is compatible with the 802.11 WLAN specifications.

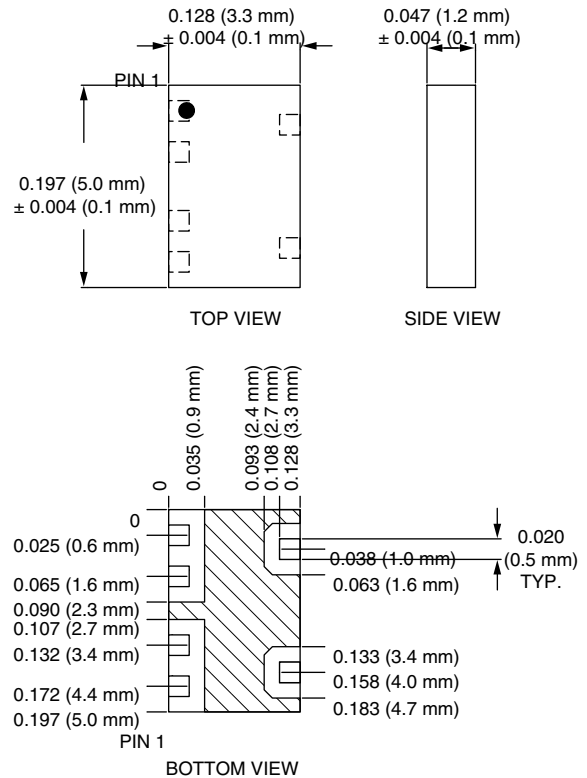

## Electrical Specifications at 25°C

Mode	Parameter	Min.	Typ.	Max.	Unit
Low Pass	Passband	2.4	2.45	2.5	GHz
	Insertion Loss		0.5	1.0	dB
	Attenuation @ 4.8 GHz	15	20		dB
	Return Loss	10	15		dB
High Pass	Passband	5.15	5.50	5.85	GHz
	Insertion Loss		0.3	0.7	dB
	Attenuation @ 2.5 GHz	20	25		dB
	Return Loss	10	15		dB

**Simulated Performance Data**

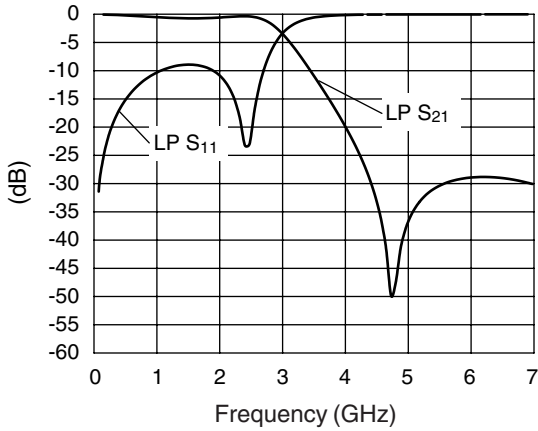

**Diplexer Low Pass Side**

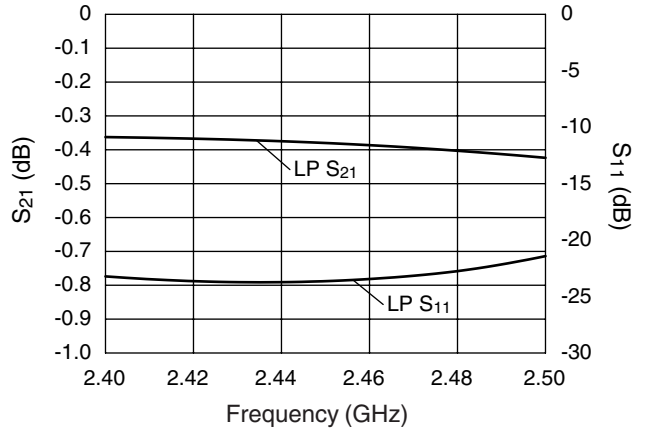

**Diplexer Low Pass In Band**

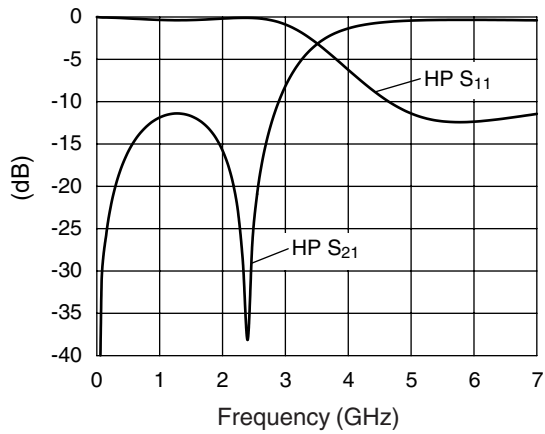

**Diplexer High Pass Side**

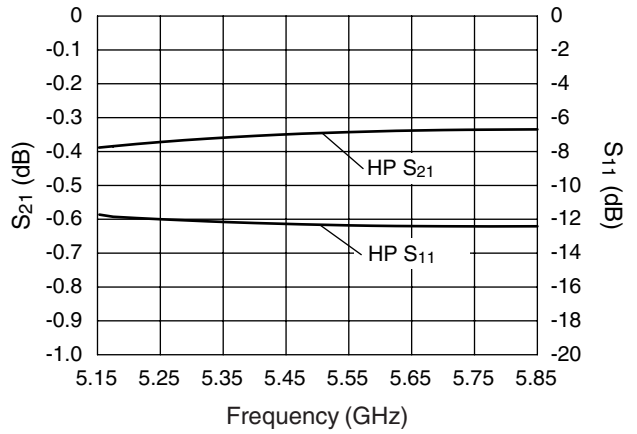

**Diplexer High Pass In Band**

**Block Diagram**

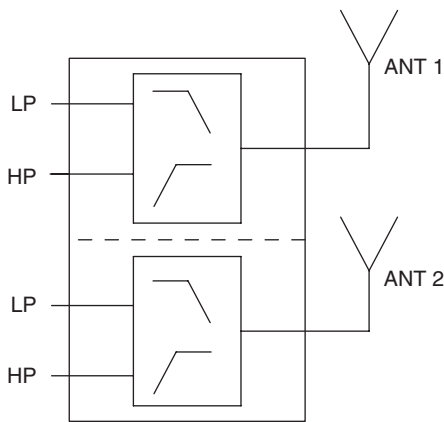

**Pin Out (Top View)**

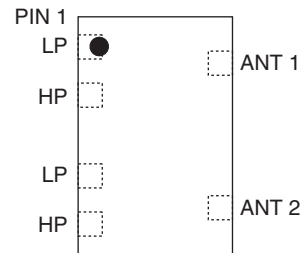

## Evaluation PCB Details

Item	Description
J <sub>1</sub> –J <sub>6</sub>	PC Mount SMA Connector
PCB <sup>1</sup>	Evaluation PCB

1. Circuit board material: Rogers RO4003.

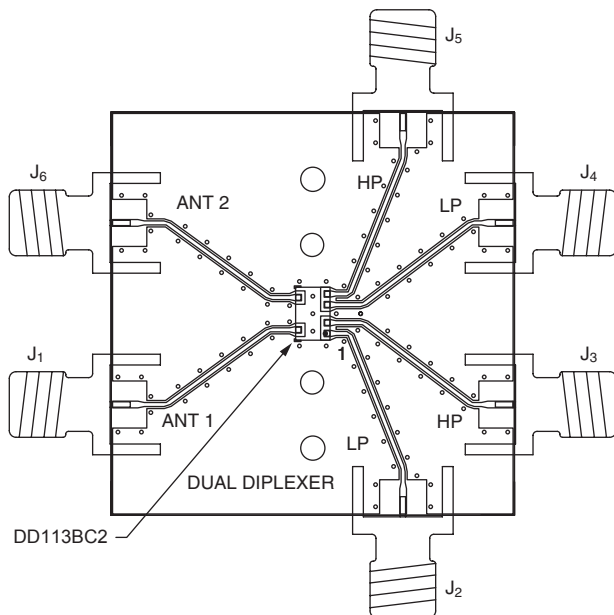

The circuit board used in the final application should employ RF circuit design techniques. RF signal lines should have 50  $\Omega$  impedance. The package bottom ground plane should be connected directly to PCB ground plane. A sufficient number of via holes should be used to connect the top and bottom ground planes. The evaluation circuit board shown is available upon request.

Represented by